



Série **XF**

Chariot élévateur thermique
de 1 à 1,8T



Simple et Robuste

HANGCHA

CHARIOTS ELEVATEURS 

www.hangcha.fr

Spécifications de la série XF 1.5 ~ 1.8t

GENERAL		HANGCHA											
		XF15D		XF15G		XF18D		XF18G					
1	Marque												
2	Modèle	XF15D		XF15G		XF18D		XF18G					
4	Energie	Diesel		GPL		Diesel		GPL					
5	Capacité de charge	Kg		1500		1750		1750					
6	Centre de charge	mm		500		500		500					
DIMENSIONS & CARACTERISTIQUES		9	Dimensions fourches - L x l x h	mm		1 200 x 100 x 35		1 200 x 100 x 35					
		11	Porte à faux AV	mm		405		405					
		12	Porte à faux AR	mm		405		430					
		13	Longueur jusqu'au fourches	mm		2285		2310					
				14	Largeur totale	mm		1080		1080			
		17	Hauteur au protégé conducteur			mm		2205		2205			
				18	Rayon de braquage (extérieur)	mm		1990		2015			
		19	Encombrement pour angle droit plus charge	mm		2395		2420					
		20	Vitesse (hors charge)	Km / h		19		18					
				21	Vitesse de levée en charge	mm/sec		580		510			
22	Vitesse de descente en charge	mm/sec				500		500					
		23	Effort au crochet chargé	N		14 600		14 800					
24	Graisement de rampe maxi avec charge	%		33		34		30					
25	Pneus	mm		6.50 -10 -10PR		6.50 -10 -10PR							
		mm		5.00 -8 -10PR		5.00 -8 -10PR							
27	Voie	mm		900		900							
		mm		920		920							
29	Empattement	mm		1475		1475							
30	Garde au sol	mm		115		115							
		mm		140		140							
POIDS		32	Poids total	Kg		2650		2760					
		33	Répartition du poids	Kg		3660 / 490		3995 / 520					
				Kg		1240 / 1410		1225 / 1540					
34	Batterie	V / Ah		12 / 60		12 / 60							
MOTEUR & TRANSMISSION		36	Moteur	Modèle		4TNE92		K21					
				Marque		YANMAR		NISSAN					
		38	Puissance nominale / r.p.m.	kw		32.8 (45 ch) / 2450		31.5 (43 ch) / 2300		32.8 (45 ch) / 2450		31.5 (43 ch) / 2300	
		39	Couple nominal / r.p.m.	N · m		142 / 1600		144 / 1600		142 / 1600		144 / 1600	
		40	No. de cylindre			4		4		4		4	
		41	Allésage x Course	mm		92 x 100		89 x 83		92 x 100		89 x 83	
		42	Emission STD.			Stage IIIA/ Tier 4		-		Stage IIIA/ Tier 4		-	
		43	Cylindrée	CC		2659		2065		2659		2065	
		44	Capacité du réservoir	L		50		50		50		50	
		45	Transmissions	Marque		HANGCHA		HANGCHA					
Type				Powershift		Powershift							
47	Nb vitesse AV / AR			1 / 1		1 / 1							
48	Pression disponible pour les accessoires	Mpa		14.5		14.5							

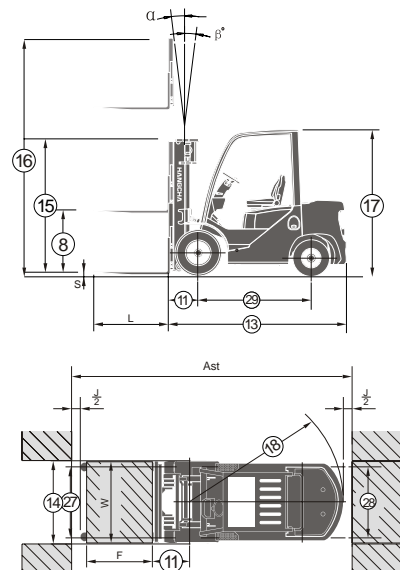

J = 200 mm Zone de sécurité
AST = J + F + (11) + (18)

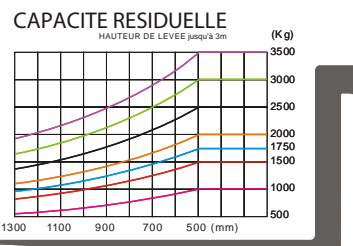

Mât de la série XF 1.0 ~ 1.8t : (pneumatique)

Type	Modèle	Hauteur de levée	Hauteur hors tout				Levée libre		Porte à faux avant		Angle d'inclinaison		Capacité										
			Déployé		Sans dossier		Avec dossier		1 / 1.5t		1.75t		Centre de gravité à 500 mm										
			Sans dossier		Avec dossier		Sans dossier		Avec dossier				AV		AR		Roues simples			Roues jumelées			
			mm	mm	mm	mm	mm	mm	mm	mm	mm	mm	Deg	Deg	1t	1.5t	1.75t	1t	1.5t	1.75t	kg	kg	kg
Mât grande visibilité	X15M300	3000	1995	3565	3955	155	155	405	410	6	12	1000	1500	1750	1000	1500	1750	1000	1500	1750			
	X15M330	3300	2145	3865	4255	155	155	405	410	6	12	1000	1500	1750	1000	1500	1750	1000	1500	1750			
	X15M350	3500	2245	4065	4455	155	155	405	410	6	12	1000	1500	1750	1000	1500	1750	1000	1500	1750			
	X15M370	3700	2395	4265	4655	155	155	405	410	6	12	1000	1500	1750	1000	1500	1750	1000	1500	1750			
	X15M400	4000	2595	4600	4955	155	155	405	410	6	12	1000	1500	1650	1000	1500	1750	1000	1500	1750			
	X15M430	4300	2745	4900	5255	155	155	405	410	6	6	950	1450	1600	1000	1450	1650	1000	1450	1650			
	X15M450	4500	2845	5100	5455	155	155	405	410	6	6	900	1400	1550	950	1400	1600	1000	1400	1600			
	X15M470	4700	2945	5300	5655	155	155	405	410	6	6	850	1350	1500	900	1350	1550	1000	1350	1550			
	X15M500	5000	3095	5600	5955	155	155	405	410	6	6	800	1300	1450	850	1300	1500	1000	1300	1500			
	X15M550	5500	3345	6100	6455	155	155	405	410	3	6	/	/	/	750	1150	1300						
Mât duplex levée libre	X15U270	2700	1910	3285	3645	1325	965	405	410	6	12	1000	1500	1750	1000	1500	1750	1000	1500	1750			
	X15U300	3000	2010	3590	3950	1425	1065	405	410	6	12	1000	1500	1750	1000	1500	1750	1000	1500	1750			
	X15U330	3300	2160	3885	4245	1575	1215	405	410	6	12	1000	1500	1750	1000	1500	1750	1000	1500	1750			
	X15U350	3500	2260	4085	4445	1675	1315	405	410	6	12	1000	1500	1750	1000	1500	1750	1000	1500	1750			
	X15U370	3700	2360	4285	4645	1775	1415	405	410	6	12	1000	1500	1750	1000	1500	1750	1000	1500	1750			
	X15U400	4000	2560	4585	4945	1975	1615	405	410	6	12	1000	1500	1650	1000	1500	1750	1000	1500	1750			
Mât triplex levée libre	X15N400	4000	1970	4680	4955	1300	1025	420	425	6	6	900	1400	1550	950	1400	1600	1000	1400	1600			
	X15N430	4300	2070	4980	5255	1400	1125	420	425	6	6	850	1350	1500	900	1350	1550	1000	1350	1550			
	X15N450	4500	2120	5130	5455	1500	1175	420	425	6	6	800	1300	1450	850	1300	1500	1000	1300	1500			
	X15N470	4700	2170	5380	5705	1585	1225	420	425	6	6	750	1250	1400	800	1250	1450	1000	1250	1450			
	X15N500	5000	2270	5695	5955	1685	1325	420	425	6	6	700	1200	1350	800	1200	1400	1000	1200	1400			
	X15N550	5500	2470	6095	6455	1885	1525	420	425	3	6	650	950	1050	750	1150	1300						
	X15N600	6000	2720	6730	7055	2100	1775	420	425	3	6	600	700	750	700	1050	1150						
	X15N650	6500	2870	7180	7455	2200	1925	420	425	3	6	/	/	/	550	800	900						
X15N700	7000	2970	7595	7955	2385	2025	420	425	3	6	/	/	/	400	550	650							

Avec tablier à déplacement latéral rapporté, réduire la capacité de 150Kg, avec tablier intégré, réduire de 100Kg.



Accédez au site HANGCHA