



ZHEJIANG HANGCHA IMP. & EXP. CO., LTD.

Factory site: 666 Xiangfu Road,
Hangzhou, Zhejiang, China (311305)

Tel: +86-571-88926735 88926755
Fax: +86-571-88926789 88132890

sales@hcforklift.com
www.hcforklift.com



Follow us on
Facebook



Follow us on
YouTube



Follow us on
WeChat



ISO14001
ISO14001:2015



ISO9001
ISO9001:2015



HANGCHA trucks conform
to the European Safety
Requirements.

2020 VERSION 1/COPYRIGHT 2020/04

HANGCHA GROUP CO., LTD. reserves the right to make any changes without notice concerning colors, equipment, or specifications detailed in this brochure, or to discontinue individual models. The colors of trucks, delivered may differ slightly from those in brochures.



2WD/4WD Rough Terrain Forklift

with capacities of 5,000kg

The World of Hangcha



HANGCHA be with you at every stage

Efficient, reliable solutions for your demands

STAGE V

With Hangcha you can meet all Stage V emissions standards which provides customer demands for value, innovation and performance. The technologies include common rail fuel systems, turbocharged Inter-cooled ,EGR + DOC + DPF. Designed and optimised to every engine model, our forklift truck maximises efficiency and reliability.

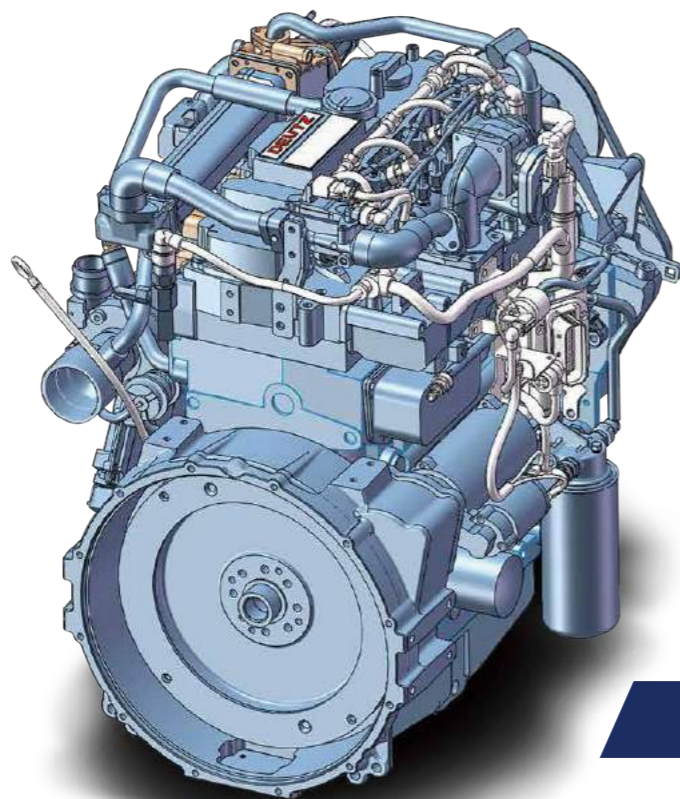

DEUTZ



Used for Deutz engine



Interactive instrument: The instrument has CAN bus communication function. The communication protocol is compatible with CANopen and SAE J1939 standards.

**Powerful/
Efficient/
Reliable**



HANGCHA Forklift with StageV

No.	Capacity	Series	Manufacturer	Engine	Drive power	Model	Emission Std.	Transmission	Power (kw/rpm)	Service brake
1	5.0t	RT	DEUTZ	TCD 3.6 L4 EU Stage V	Diesel	CPCD50-XW95E-RT2	Stage V	China	55.4/2300	Hydraulic
2	5.0t	RT	DEUTZ	TCD 3.6 L4 EU Stage V	Diesel	CPCD50-XW95C-RT4	Stage V	China	55.4/2300	Hydraulic

Note: Stage V applied for European Union also including Israel and Turkey

CONCEPT

HANGCHA 5t rough terrain forklift with 2WD/4WD was developed on the basis of the XF series of Hangcha. It adopts the Deutz and Cummins engine, which is powerful and reliable, easy to maintain; It can adapt to the rugged roads in the stone market, timber market, construction sites, etc., as well as the wet and slippery roads in rain and snow.

2WD
ROUGH TERRAIN

4WD
ROUGH TERRAIN



Safety

- / Thanks to the steering oil circuit and the brake oil circuit are independent of each other, thereby reducing the interference of the brake on the steering, the hydraulic braking system is very safe.
- / With the structure of brake valve plus the accumulator, it is safer and reliable.
- / The returned oil filtration device is taken as the standard configuration to extend the service life of the hydraulic elements.
- / OPS function is available for option, work is safer and reliable.

Comfort

- / With the suspension and integrated overhead guard, full-floating transmission, complex engine shock absorber and suspension seat, driving is more comfortable, and the vibration and noise of the truck can be reduced.
- / The extra foot space is provided to reduce operator fatigue significantly, non-slip step makes getting in and out easy and safe. The new designed steering wheel, new brake system and the easy-to-operate levers provide total handling operation.
- / Excellent upward visibility is provided by a large roof screen, in fact, visibility all-round is excellent.

Powerful and reliable engine

- / The 3.6-litre DEUTZ EURO III B/Tier4F-compliant engine produces its peak power (74.3hp/55.4kw) and torque (390Nm) at engine speeds as low as 1300 rpm for great responsiveness.

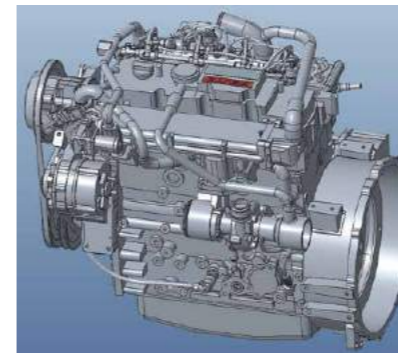

Easy maintenance

- / The two-piece design makes the floorboard easy to lift and remove for access to the power train.
- / The radiator cover can be turned easily by hand to enable quick inspections or servicing.



The easy-to-open hook provides quick access to the engine compartment

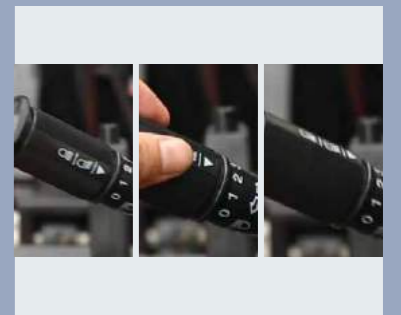

Three forward gears- Suspension hydraulic transmission with three forward gears, top speed reach 25km/h



Oscillating steer axle allows either wheel to step over obstacles keeping the truck and load level



To achieve maximum productivity, a rough terrain forklift operator needs to be comfortable and in control. We've created a workplace that gets the best from your operators and your machinery

Reliability

- / The reinforced truck chassis with CAE simulation software, optimized design is conducted for the tilt cylinder and steering drive axle installation.
- / Dual air filters and two-stage air filter are taken as the standard configuration to guarantee that the engine can operate for long time and under the optimal status.
- / Deutz engine adopt, "TCI+CR+EGR+DOC" technical route. Adopt EURO III B/Tier4F emission can be met, and it is energy-saving and environment-friendly; A turbo engine further enhances performance at low engine speeds for improved power and tractive effort.



The differential is specifically designed for rough terrain and features manual differential lock providing ultimate traction during inclement weather conditions and rough operating surfaces, it differerntial lock prevents power loose when one wheel spins.



Full-floating hydraulic drive gear box has the function of switching between 2WD and 4WD, and can provide higher run speed and stronger climbing ability;

Higher specification fork mounting level-3B, more weight can be loaded.



Front tyre

Rear tyre



Productivity

The transmission system gets the maximum performance from the engine without reaching high revolutions, which provides fuel saving, noise level reduction and engine life increase.



The new Dynamic load sensing hydraulic steering system contributes to reduce loss of hydraulic and improve energy efficiency.



The new efficiency lighting system employs LED illuminant and new type reflector to reduce energy consumption, improve significantly illumination performance and prolong work time.

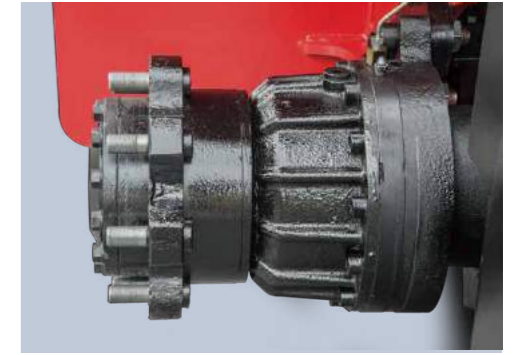
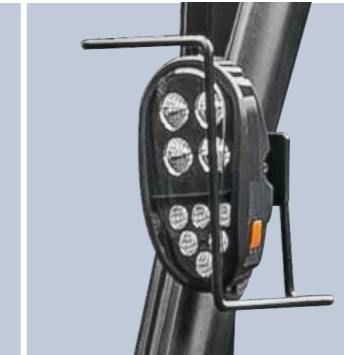

Wet brake offers maximum service life for your brake system.

Maneuverability

The distance to ground is 370mm, it offers greater maneuverability and keep the truck moving in the roughest of applications, and yet we keep a very low center of gravity, by using a distributed weight in the forklift, giving it an excellent stability.





Standard specification

- / Counterweight cover
- / Full-suspension seat
- / Dual air filters
- / High-position exhaust
- / Fuel tank cover (with lock)
- / Fan protection device
- / Rear working light
- / Alarm light
- / Emergency switch
- / Right and left reflective mirrors
- / PVC ceiling
- / Wet brake

Options

- / Front windshield and wipers
- / Cab (warm air blower and fan are available for option)
- / Solid tyre
- / Engine cover with lock
- / Engine cover with dual sound insulation cushion
- / Engine cover with lock+ dual sound insulation cushion
- / Mud baffle provided with rigging hole
- / 3rd/4th/5th valve
- / Voice type reversing buzzer
- / Blue light lamp
- / Low-temperature cold start-up battery (-20 C)
- / OPS system
- / OPS system & Compatible with Sequential Seat Belt Interlock System

